

# DA TRAMO<sup>®</sup>

# estal

www.estal.com  
+34 972 821 676



Modelo registrado/  
Registered model/  
Modèle enregistré

 FEA 15

 EXTRA FLINT

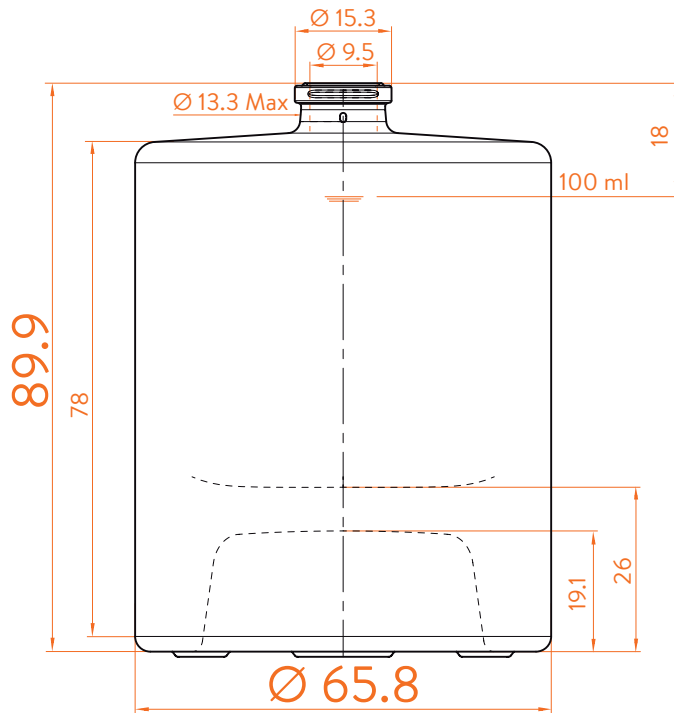

## DATOS TÉCNICOS TECHNICAL DATA DONNÉES TECHNIQUES

<b>Peso / Weight / Poids</b>	360 gr
<b>Altura total / Total height / Hauteur totale</b>	89,9 mm
<b>Diámetro del cuerpo / Body diameter / Diamètre du corps</b>	65,8 mm
<b>Ø interno boca / Ø inner mouth / Ø intérieur bouche</b>	9,5 mm
<b>Capacidad a verter / Brimfull / Capacité Ras-Bord</b>	108 ml

## 100 ml

At first the DA TRAMO range is proposed in 30, 50 and 100 ml.  
Following business opportunities, other sizes - from miniature 5 cl to big sizes 300 cl will be added to the range.

The elements detailed in this document are not contractual. They are only indicative.